

ClearTone[®]

Fetal and Vascular Dopplers

User Manual for CT150 Series, CT150R Series, CT250 Series, CT250R Series



CE0086

Thank you for choosing ClearTone® from CooperSurgical, Inc. We believe you have purchased the finest handheld Doppler on the market today. Your total satisfaction is our highest priority as we strive to continually improve our products and services. Please contact us with any suggestions. We look forward to enjoying a long-term relationship with you!



CooperSurgical, Inc.
95 Corporate Drive
Trumbull, CT 06611 USA



Year of manufacture
located on the device.

Here's how you can reach us...

Phone: 1-800-243-2974
(203) 601-5200

Fax: 1-800-262-0105

e-mail us at: e-mail@coopersurgical.com

visit our website at: www.coopersurgical.com

Table of Contents:	Page
Intended Use/Contraindications/Warnings	1
Description of Product	3
Operation and Installation	4
Obtaining Doppler Signals	6
Maintenance and Cleaning	8
Replacing Batteries.....	9
Troubleshooting	10
Clinical References	11
Accessories	11
Specifications	11
Warranty	15
Explanation of Symbols	16

Please read the manual carefully and become familiar with the operation, features and maintenance of your Doppler prior to using the device or accessories.



EMERGO EUROPE
Molenstraat 15
2513 BH, The Hague
The Netherlands

Intended Use

Obstetric (2 and 3 MHz Probes)

This product will be used to detect fetal heart beats as an aid for determining fetal viability.

Vascular (5 and 8 MHz Probes)

This product will be used to detect blood flow in veins and arteries for assisting in the detection of peripheral vascular disease.

Caution

- U.S. Federal law restricts this device to sale by or on the order of a licensed practitioner.

Contraindications

Warnings

- The vascular probes (5 and 8 MHz) are not for fetal use.
- The ultrasound probes are not to be used on or near the eyes.
- The device is for use only on intact skin.
- Do not plug any part of this device into a telephone or modem system.
- This device is not intended for use with HF surgical equipment.

If there are questions or concerns regarding these warnings or contraindications, please do not hesitate to contact CooperSurgical for further clarification.

Caution

- Dropping the ClearTone, probe or accessories may cause damage to the housing or electronics.



In order to preserve, protect and improve the quality of the environment, protect human health and utilize natural resources prudently and rationally – do not dispose of waste electrical or electronic equipment (WEEE) as unsorted municipal waste. Contact local WEEE disposal sites.

Safety of Ultrasound

The ClearTone was designed with physician and patient safety in mind. In early design phases all potential hazards were eliminated or reduced to As Low As Reasonably Achievable (ALARA) by adhering to good design practices and industry wide safety standards. Ultrasound procedures should be performed with the ALARA principle in mind when delivering ultrasound energy into the body.

The following official statements from the American Institute of Ultrasound Medicine (AIUM) are provided for your general information regarding the safe use of ultrasound.

Clinical Safety

Approved March 1997, October 1982

Diagnostic ultrasound has been in use since the late 1950s. Given its known benefits and recognized efficacy for medical diagnosis, including use during human pregnancy, the American Institute of Ultrasound in Medicine herein addresses the clinical safety of such use:

There are no confirmed biological effects on patients or instrument operators caused by exposures from present diagnostic ultrasound instruments. Although the possibility exists that such biological effects may be identified in the future, current data indicate that the benefits to patients of the prudent use of diagnostic ultrasound outweigh the risks, if any, that may be present.

Prudent Use

Approved May 1999

The AIUM advocates the responsible use of diagnostic ultrasound. The AIUM strongly discourages the non-medical use of ultrasound for psychosocial or entertainment purposes. The use of either two-dimensional (2D) or three-dimensional (3D) ultrasound to only view the fetus, obtain a picture of the fetus or determine the fetal gender without a medical indication is inappropriate and contrary to responsible medical practice. Although there are no confirmed biological effects on patients caused by exposures from present diagnostic ultrasound instruments, the possibility exists that such biological effects may be identified in the future. Thus ultrasound should be used in a prudent manner to provide medical benefit to the patient.

Safety in Training and Research

Approved March 1997, March 1983

Diagnostic ultrasound has been in use since the late 1950s. There are no confirmed adverse biological effects on patients resulting from this usage. Although no hazard has been identified that would preclude the prudent and conservative use of diagnostic ultrasound in education and research, experience from normal diagnostic practice may or may not be relevant to extended exposure times and altered exposure conditions. It is therefore considered appropriate to make the following recommendation:

In those special situations in which examinations are to be carried out for purposes other than direct medical benefit to the individual being examined, the subject should be informed of the anticipated exposure conditions, and of how these compare with conditions for normal diagnostic practice.



Description of Product

The CooperSurgical ClearTone Doppler is factory configurable to include many different features and product enhancements. Along with user interchangeable ultrasound transducers, the ClearTone device is well suited to meet your specific needs.

Main Unit

The main handheld unit is ergonomically designed to fit the palm of your hand with comfort and allow easy access to each control feature. Each unit is individually tested and inspected to ensure the highest quality standards.

SSQ – Superior Sound Quality. Every ClearTone Doppler is designed with a state of the art sound system that produces excellent sound quality and long-term reliability.

Recharge – We offer the ease of use of a rechargeable system or the attractive cost of a non-rechargeable unit. Either way, the ClearTone Doppler battery system has been designed with your long-term battery life needs in mind.

LCD Display – The LCD display (optional) allows you to view the fetal heart rate in large, easy to read digits, monitor battery life and battery recharging, observe signal strength indicators, and multiple diagnostic indicators that ensure your unit is functioning at peak performance levels.

Units without LCD display incorporate bright, easy to read LED indicators that also allow you to monitor battery life and battery recharging as appropriate to your unit.

Probes

ClearTone ultrasound transducers were designed to meet your specific applications needs. Each probe has been ergonomically designed for comfort while providing excellent maneuverability for locating the fetus or vascular target.

Each probe is carefully measured and tested to ensure it meets exacting performance standards.

2 MHz - Late term obstetrical examination. This probe frequency is typically used during the last trimester for deep fetal positions associated with larger women. Waterproof versions of the 2 MHz probe are available.

3 MHz – Early and general-purpose obstetrical examination. This probe frequency is a general use model ideal for most stages of fetal examination. Fetal heart sounds can be heard as early as 12 weeks and sometimes sooner depending on the position and size of the fetus.

5 MHz – This standard “pencil” style probe is an excellent vascular tool for locating deep specific vessels in the peripheral vascular system. The narrow grip and small face of the probe make it ideal for maneuvering for maximizing the signal.

8 MHz – This standard “pencil” style probe is an excellent vascular tool for locating shallow specific vessels in the peripheral vascular system. The narrow grip and small face of the probe make it ideal for maneuvering for maximizing the signal.

Operation and Installation

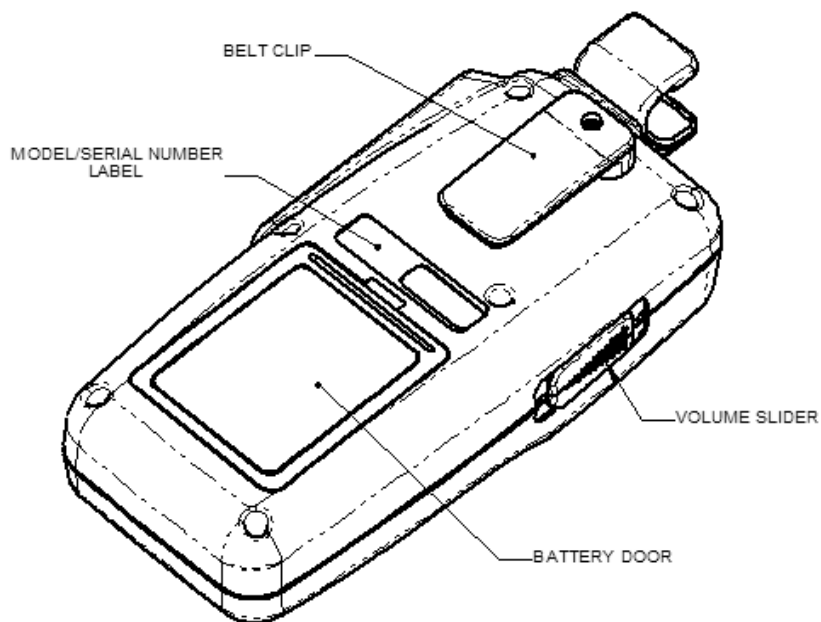
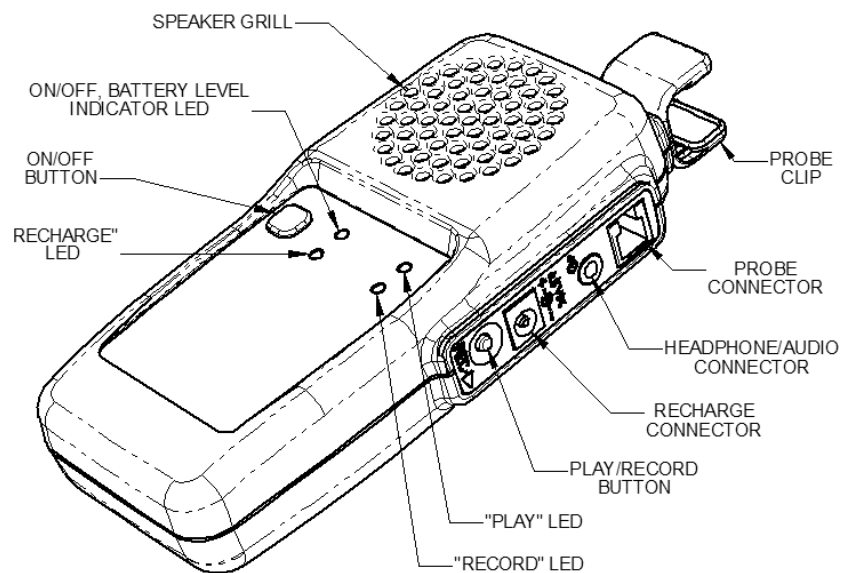

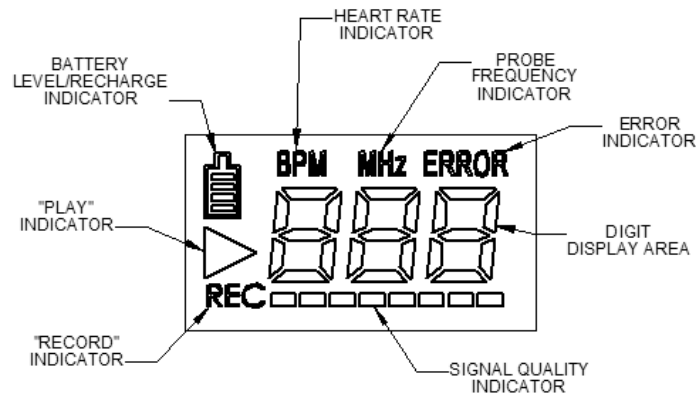

LCD Panel for Display Units Only

Turning Unit On/Off

Turn the unit on by pressing the On/Off button. LED or LCD indicators (depending on the model) indicate power status.

The ClearTone automatically shuts itself off after 3 minutes if it is not being used. This complete power shutdown preserves the life of the batteries and ensures the unit will be ready for operation in case it was accidentally left on.

Diagnostic Monitoring (LCD Display units only)

Once the unit is on, the ClearTone display units perform a series of diagnostic checks. The unit first checks and temporarily displays the frequency of the probe that is being used. This display will not reappear unless the probe is changed or the power is cycled, in which case the display will again temporarily confirm the frequency of probe that is connected.

The unit then checks for proper internal operating temperature, battery voltage, reference voltage and power supply voltage levels. If any of these characteristics are out of range, the display will show the ERROR indicator and a failure code associated with the diagnostic error. Diagnostic functions are periodically checked while the unit is on to ensure the Doppler is operating at peak performance. Refer to the Troubleshooting section for a listing of failure codes.

Battery Monitoring

All ClearTone Doppler units perform continuous battery monitoring and give a visual indication of battery level. Display units use a multiple level battery-shaped indicator that indicates the voltage level of the battery. The battery outline will flash when the battery level is very low, indicating that the user should change the batteries soon after the current examination is complete.

Non-display units use the On/Off LED as a battery indicator by flashing at a low rate (approximately once per second) when the battery level is low. Several exams can still be performed in this state of operation. The battery indicator will flash at a higher rate (approximately twice per second) when the battery level is very low. The user should change the batteries soon after the current exam is complete.

Recharging (Rechargeable units only)

Warnings

- Do not use any other wall adaptor unit other than that supplied by CooperSurgical. See the Accessories section for reordering of parts information.
- Do not attempt to recharge alkaline batteries. Major damage to electrical components is likely to occur.

It is recommended that the ClearTone Doppler unit to be recharged prior to first use. To recharge the unit, plug the recharge jack from the wall adaptor into the unit's recharge connector. For display units, the battery shaped indicator will cycle in a repeated rising pattern to indicate the unit is recharging. For non-display units, the Recharge LED will turn on.

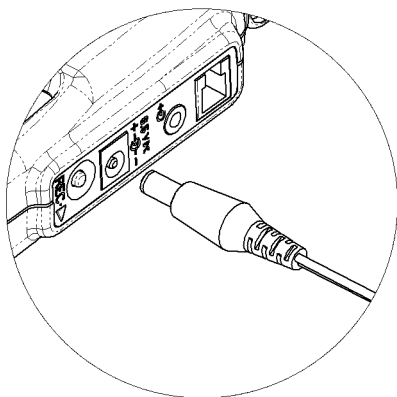

Recharge Jack from power supply plugs into connector

8.5 VDC
+ — — —

The recharge cycle will be limited to 14 hours or until the maximum battery voltage level has been reached. Once the recharge cycle has been discontinued normally, the LCD indicator or the Recharge LED will flash at a low rate. The unit will not overcharge the batteries. If it determines that the batteries do not require charging, the charge cycle will be interrupted after 30 seconds.

Obtaining Doppler Signals

Caution

- Doppler examinations should be performed only by trained individuals.

For any Doppler examination, it is essential that an adequate supply of coupling gel is used to transmit the ultrasound energy from the probe to the surface of the skin. Re-apply more gel if it starts to dry out or spread so thinly that an air gap occurs between the probe and the skin. It is not necessary to cover the entire surface of the probe, only the probe face. Applying too much gel makes the unit difficult to clean and does not aid in the performance of the probe.

Volume Slider

The audio level can be adjusted using the Volume Slider. Moving the slider up will increase the volume, while moving it down will decrease it.

Signal Quality Indicator (Display units only)

An inadequate signal can produce erroneous rates from the heart rate calculation. The signal level that is being obtained is shown on the Signal Quality Indicator bars. This indicator provides a visual aid in obtaining a strong audio signal by showing the pulsatile nature of the signal. A large difference between the highest and lowest signal bars that are lit confirms that the quality of the signal is good and thus ensures the heart rate calculation is operating at peak performance.

The heart rate can be verified manually by counting the audible beats for 20 seconds and multiplying by 3, or for 15 seconds and then multiplying by 4. Counting for less than 15 seconds is not recommended due to a decrease in accuracy with the small sample size.

Obstetrical

Fetal heart sounds are quite different from peripheral vascular blood flow sounds. Fetal sounds are typically much lower in frequency and much higher in rate. For early term fetal detection, start the probe at the pubic bone and slowly move along the midline – rocking the probe slowly from side to side until a heartbeat is heard. For mid to late term fetal detection the best chance of finding the heart sounds are to start on the fundus and move toward the navel and from one side of the abdomen to the other, slowly rocking the probe until the heartbeat is heard. The fetal heart reminds many people of a galloping horse and can vary in tone from a distant swishing sound to a hard clapping sound depending on the position of the baby and probe.

Many times when attempting to detect the fetal heart, the maternal vascular sounds are heard instead of (or in some cases, in addition to) the fetal sounds. These maternal sounds can come from one of the major arteries, the placenta or the umbilical cord. The maternal vascular sounds are typically higher in frequency at a lower rate. The heart rate calculation will display either the maternal rate or the fetal rate, whichever portion of the signal is stronger.

If the fetal heart sounds cannot be located using the procedure as described above, a second exam should be performed using another commercially available fetal monitor as a repeated test.

5 and 8 MHz Vascular

Peripheral arterial sounds are typically higher in frequency. For the best sounds, angle the probe approximately 45 degrees from the skin surface over the general location of the vessel. Slowly move the probe side to side and vary the angle of the probe until the vascular sounds are heard. Changing the angle of the probe has an effect on the frequency of the sound. The steeper the probe angle is, the higher the frequency of the sound.

Peripheral venous sounds are not typically periodic and vary greatly depending on patient movement and breathing. These sounds are more like the wind at the ocean and vary in pitch as the patient moves or breathes.

Maintenance and Cleaning

Warnings

- The ClearTone is not designed for liquid immersion. Do not soak the Doppler main unit or probes in liquids. Use only spray or wipe cleaners and disinfectants. **Do not use products containing bleach.**
- The ClearTone is not designed for sterilization processes such as autoclaving, gamma radiation or hydrogen gas.
- The ClearTone is not intended to be used on open skin. If there is evidence of open wound contamination, disinfect the probe before using again as described below.

The ClearTone Doppler requires very little maintenance. However, it is important to the continuing function of the unit and the health of the patients that the unit is cleaned and examined regularly per the following guidelines:

After every examination:

Excess gel should be wiped off prior to docking the probe. Probes and main unit should be cleaned with a damp cloth using warm water or presaturated isopropyl alcohol wipes or spray. In particular, pay close attention to clean the seams along the plastic lines at the probe face but **do not allow water or spray to enter through the connectors or speaker grill.**

To disinfect unit, use commercially available spray or wipe disinfectants registered with the EPA. Clorox[®] Broad Spectrum Quaternary Disinfectant is the only disinfectant that is CooperSurgical approved for use with the ClearTone product. Follow the manufacturer's instructions and wipe unit until it is dry of solutions. Examiners should wash hands and change gloves after every exam. Refer to local and hospital policies for cleaning and disinfection policies.

Store unit in a clean area free from dust and debris. Follow temperature and humidity guidelines as specified at the end of this manual.

Warning

- If the unit is to be stored for longer than 90 days without use, remove the batteries prior to storage.

Periodically (at least annually):

Inspect the main unit and probes for signs of cracks or breaks in the mechanical housing. Inspect cables and connectors for signs of wear or failure. The user should discontinue use of the unit with any sign of loss of housing integrity. Contact CooperSurgical for service.

It is recommended that rechargeable batteries be replaced annually.

Replacing Batteries

Warnings

- Replace rechargeable batteries only with batteries supplied by CooperSurgical. See the Accessories section for reordering of parts information.
- The battery compartment only accepts AA size batteries. See the Accessories section for reordering of parts information.

Open the battery compartment by depressing the tab and pulling outward on the battery door. Remove the existing drained batteries by pushing on the end of the battery that compresses the battery contact spring and lift upwards. It is acceptable to carefully use a simple tool, such as a pen, to assist in lifting the batteries out.

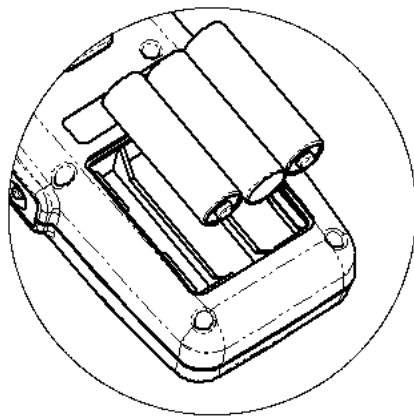

Batteries slide into compartment

Replace the batteries by paying close attention to the polarity indicators on the battery and the polarity indicators on the battery holder in the compartment. Positive (+) aligns with positive (button) and negative (-) aligns with negative (spring). Insert the battery such that the spring contacts are loaded first and then press the battery firmly into place. After all three have been inserted, replace the battery door.

Warning

- If the batteries have been inserted incorrectly, the unit will not function but the ClearTone will not be damaged.

Troubleshooting

Warning

- Use alternate equipment in case of unit failure. Call CooperSurgical's Service Department if the probe or main unit malfunctions at 1-800-444-8456.

Caution

- Do not drop or mishandle the ClearTone or probes. Damage to sensitive electrical components and transducers is likely to occur.

Poor sound quality

Inadequate gel use

Try to relocate the probe for a better signal – refer to Signal Strength Indicator

Improper choice of probe Frequency

Interference from other equipment

Probe interconnect cable or battery contacts may be intermittent

Debris in the speaker may cause poor sound

Device damage from dropping the ClearTone, probes or accessories

Heart Rate inaccurate

Try to relocate the probe for a better signal – refer to Signal Strength Indicator

For OB, ensure maternal sounds are not mixing with fetal sounds

Ensure by manual counting that the rate is between 50 and 220 BPM

Battery indicator flashing

Consult the Battery Monitoring section; replace batteries as described in the Replacing Batteries section.

Probe frequency does not match the connected probe

Check probe that is attached to ensure it is the correct one, or check to see if probe is attached. If the correct probe is being used, contact CooperSurgical's Service Department at 1-800-444-8456.

Error 5 or 7

Batteries are low. They require replacement or recharging.

Recharge indicator flashing

Recharge cycle is complete or the batteries didn't require recharge.

Recharge indicator off after charging

Battery level error has occurred – refer to Diagnostic Codes and contact service.

Rechargeable unit does not hold a charge

Verify that the correct recharge adaptor is being used - Use only CooperSurgical products.

Batteries are old - Refer to Replacing Batteries section.

Radio Frequency Interference

The ClearTone was tested for immunity to electromagnetic interference at a level of 3 V/meter. Interference during normal operation may occur in the presence of fields stronger than 3 V/meter. If this occurs, try to increase the distance between the ClearTone and the source of interference. Contact CooperSurgical for more information.

Diagnostic Codes – Contact CooperSurgical’s Service Dept. at 1-800-444-8456

1 – Temperature too low	5 – 5 Volt Supply too low
2 – Temperature too high	6 – 5 Volt Supply too high
3 – Reference Voltage too low	7 – Battery Voltage too low
4 – Reference Voltage too high	8 – Battery Voltage too high

Reference materials for Obstetrical and Peripheral Vascular testing:

Handbook of Fetal Heart Rate Monitoring; Julian T. Parer, 1997

Doppler Ultrasound and Its Use In Clinical Measurement; Peter Atkinson and John P. Woodcock, 1982

Noninvasive Diagnosis of Peripheral Vascular Disease; W. Robert Felix, Jr., 1988

Current Noninvasive Vascular Diagnosis; Ali F. Aburahma, Edward B. Diethrich, 1988

Accessories

To order accessories (gel, batteries, rechargers, probe cleaner, cables), contact CooperSurgical Service at 1-800-645-3760 or (203) 601-5200 to order by phone.

Specifications

Degree of protection against electric shock:

 Type B Applied part

 Class II Equipment

Degree of protection against ingress of water:

2 MHz Waterproof: IPX7 – entire probe and cable excluding connector

All other probes: IPX4 – extending 2.5 cm from tip

IPX1 – entire probe 2.5 cm from tip, excluding connector

Designed and tested to meet:

IEC601-1, IEC60601-1-2, IEC60601-1-4, IEC60601-2-37, EN5011-A

Dimensions (h x w x l): 140 x 70 x 35 mm

Weight: 320 grams

Operating temperature:	10 to 40 °C
Operating humidity:	30 to 75 %
Transport/Storage temperature:	-20 to 50 °C
Transport/Storage humidity:	5 to 90%, non-condensing (beyond 30 days, battery to be stored between -20 and 30 °C)
Battery type and voltage:	3 – AA Alkaline 1.5 volt (for non-rechargeable units) 3 – AA NiMH 1.5 volt (for rechargeable units)
Battery life:	Batteries provided by CooperSurgical: 1000, 1-minute exams (NiMH) 1250, 1-minute exams (Alkaline)
Audio bandwidth and power:	350 Hz – 2 KHz, 0.5 W
Record sampling rate, duration:	4 KHz, 32 seconds
Heart rate calculation accuracy:	± 3 BPM over range 50 to 220 BPM
Audio cable pin out: (L250AR version only)	3.5 mm stereo plug Tip – Audio out Ring – Audio out Shaft – Ground

Operating Conditions: There are no user controls which affect the ultrasound output.



Attention: Consult Accompanying Documents

Transducer Model: CTP-5 **Operating Mode:** Continuous-Wave (cw)
Application(s): Peripheral Vascular

<i>ACOUSTIC OUTPUT</i>		<i>MI</i>	<i>I_{SPTA,3}</i> (mW/cm ²)	<i>I_{SPPA,3}</i> (W/cm ²)	
Global Maximum Value		0.04	223	0.22	
Associated Acoustic Parameter	P _{r,3} (Mpa)	0.09			
	W _o (mW)		12.8	0.013	
	f _c (MHz)	5.3	5.3	5.3	
	Z _{sp} (cm)	0.85	0.85	0.85	
	Beam Dimensions	x ₋₆ (cm)		0.4	0.4
		y ₋₆ (cm)		0.6	0.6
	EBD	Az (cm)		0.4	
Ele. (cm)			0.8		

Transducer Model: CTP-8 **Operating Mode:** Continuous-Wave (cw)
Application(s): Peripheral Vascular

<i>ACOUSTIC OUTPUT</i>		<i>MI</i>	<i>I_{SPTA,3}</i> (mW/cm ²)	<i>I_{SPPA,3}</i> (W/cm ²)	
Global Maximum Value		0.03	229	0.23	
Associated Acoustic Parameter	P _{r,3} (Mpa)	0.09			
	W _o (mW)		13.9	0.014	
	f _c (MHz)	8.0	8.0	8.0	
	Z _{sp} (cm)	0.66	0.66	0.66	
	Beam Dimensions	x ₋₆ (cm)		0.2	0.2
		y ₋₆ (cm)		0.4	0.4
	EBD	Az (cm)		0.3	
Ele. (cm)			0.6		

Obstetrical Probe Information:

	Model Number	
	CTP-2 CTP-W	CTP-3
$I_{SATA(max)}$ (mW/cm ²)	19.6	17.0
P_o (mW)	48.0	24.4
Effective Radiating Area (cm ²)	2.45	1.57
Ultrasound Frequency (MHz)	2.1 MHz	3.2 MHz
Pulse Duration	CW	CW
Repetition Freq.	CW	CW

I_{SATA} the **spatial-average temporal-average intensity** (mwatts per cm²).

$I_{SPTA.3}$ the **derated spatial-peak temporal-average intensity** (mwatts per cm²).

$I_{SPPA.3}$ the **derated spatial-peak pulse-average intensity** (watts per cm²).

MI the **Mechanical Index**.

$P_{r.3}$ the **peak rarefactional pressure** (megapascals) associated with the transmit pattern giving rise to the value reported for MI.

W_o the total time-average **ultrasonic power** (mwatts).

f_c the probe **center frequency** (MHz).

z_{sp} the axial distance at which the reported parameter is measured (cm).

x_{-6}, y_{-6} are the **-6dB beam dim.** in the x-y plane where z_{sp} is found (cm).

EBD the **entrance beam dimensions** (cm). These dimensions are the same as the dimensions of the transmit crystal.

Measurement Uncertainties:

Power:	+34, -42%
Pressure:	+11, -16%
Intensity (I_{spta}):	+23, -26%
Frequency:	± 5%

Acoustic Output Parameters are measured in water. Derated values, denoted by the subscript “.3”, take into account a conservative level of attenuation that would be encountered in the human body. The derated intensity values ($I_{.3}$) are obtained from water values of intensity (I_w) at a depth of z calculated by:

$$I_{.3} = \exp(-0.23 \cdot 0.3 \cdot f \cdot z) \cdot I_w$$

(where f is the probe frequency in MHz and z is the depth in centimeters)

The derated peak rarefactional pressure is calculated from the value of measure water (pr) by:

$$P_{r.3} = \exp(-0.115 \cdot 0.3 \cdot f \cdot z) \cdot p_r$$

(where pressure is given in megapascals)

Additional Output Reporting Information for IEC 61157

4 MHz: $I_{ob} < 91 \text{ mW/cm}^2$

5 MHz: $I_{ob} < 51 \text{ mW/cm}^2$

8 MHz: $I_{ob} < 47 \text{ mW/cm}^2$

The 2 MHz, 2 MHz WP and 3 MHz obstetrical probes are exempt from the declaration requirements of IEC61157. These probes meet the conditions: $I_{ob} < 20 \text{ mW/cm}^2$, $I_{spta} < 100 \text{ mW/cm}^2$, and $P_r < 1 \text{ MPa}$. I_{ob} is output power divided by beam area.

Note that parameter Z_{sp} in the probe reporting tables is the same parameter as I_p in IEC 61157.

Warranty and Servicing Policy

This warranty is in lieu of all other warranties, expressed or implied. CooperSurgical warrants this ClearTone Doppler against defects in material or workmanship as follows:

Parts CooperSurgical will repair or replace parts in exchange for defective parts for the specified life of the device of five (5) years after date of original purchase with no charge for the parts. CooperSurgical reserves the right to determine whether a part should be repaired or replaced.

Labor CooperSurgical will repair this instrument with no labor charge for a period of one (1) year after the date of original shipment when it is shipped to the CooperSurgical Service Center. Transportation and insurance to the Service Center are to be prepaid by the purchaser.

Limitations - This product is to be used only for the intended purpose and labeled indications presented in the literature accompanying the product. This warranty shall not apply to any products repaired or altered by anyone not authorized in writing by CooperSurgical. CooperSurgical makes no warranty of the results to be obtained. CooperSurgical's sole responsibility shall be to replace or repair this product under the terms stated above and does not cover loss or damage from external causes such as, but not limited to, weather, theft or abuse. **This warranty does not apply to batteries, shipping case or other accessories, or to damage from shipping, tampering, misuse or negligence.** Preventive maintenance, the refinishing or replacement of any cosmetic defect or deterioration, or the replacement of batteries unless damaged by a component failure is not covered by this warranty. CooperSurgical will not be responsible for any loss, damage or injury resulting from delay in rendering service under this warranty. COOPERSURGICAL SHALL NOT BE RESPONSIBLE FOR ANY SECONDARY CHARGES OR CONSEQUENTIAL DAMAGES FROM ANY BREACH OF ANY WARRANTY, EXPRESSED OR IMPLIED. Since some states do not allow the exclusion or limitation of consequential damages, some of this limitation may not apply to you. This warranty gives you specific legal rights, and you may also have other rights which vary from state to state.

To return products to CooperSurgical:

1. Call CooperSurgical to obtain a Return Authorization and to receive any final instructions prior to shipping
2. Clean the product prior to shipping
3. Ensure the device is well-packaged and suitable for shipment
4. Send the product to:
Service Center
CooperSurgical, Inc.
95 Corporate Drive
Trumbull, CT 06611 USA

If you should have questions, please call 1-800-243-2974 for Customer Service, 1-800-444-8456 for Technical Support or (203) 601-9818 for International calls.

Explanation of Symbols



Reorder Number



Serial Number



Latex Free



ATTENTION:
See instructions for use.



Manufacturer



Date of Manufacture



Symbol indicates that the device should be sent to the special agencies according to local regulations for separate collection after its useful life.



Product conforms to the Medical Device Directive 93/42/EEC



Authorized Representative in the European Community.



Keep Dry



Type B Applied Part



Class II Equipment

ClearTone[®] and CooperSurgical are registered trademarks of CooperSurgical, Inc.

Clorox[®] is a registered trademark of The Clorox Company

© 2013 CooperSurgical, Inc.

CooperSurgical

Made in the USA

95 Corporate Drive • Trumbull, CT
06611 USA
Phone: (800) 243-2974
Fax: (800) 262-0105
www.coopersurgical.com

International
Phone: (203) 601-9818
Fax: (203) 601-4747



EMERGO EUROPE
Molenstraat 15
2513 BH, The Hague
The Netherlands